

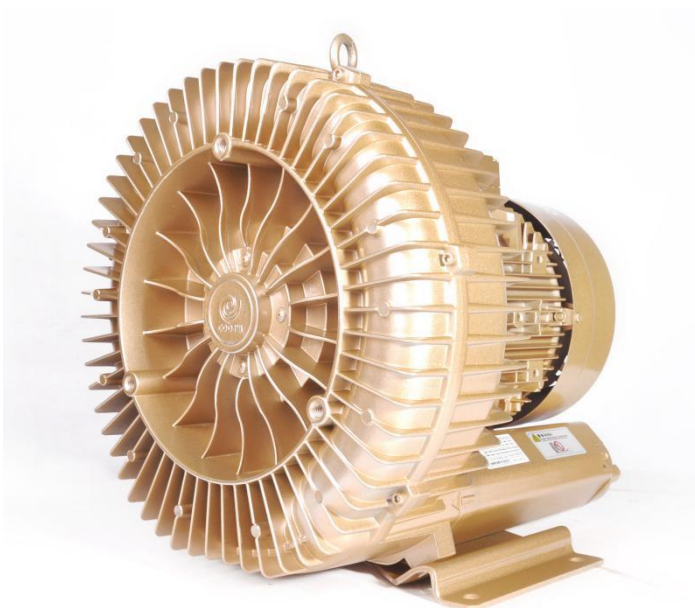

# Instruction Manual

Side Channel Blower



Dongguan Foersheng Intelligent M&E Co., Ltd  
Hong kong Fenglisheng Group Company Limited



# Table of Contents

<b>1</b>	<b>Safety</b> .....	<b>3</b>
<b>2</b>	<b>Product Description</b> .....	<b>4</b>
2.1	Operating Principle .....	5
2.2	Application .....	5
2.3	Optional Accessories.....	5
2.3.1	Pressure relief Valve .....	5
2.3.2	Inlet Filter .....	6
2.3.3	Silencer.....	6
<b>3</b>	<b>Installation</b> .....	<b>7</b>
3.1	Installation Conditions.....	7
3.2	Connecting Lines / Pipes .....	8
3.2.1	Suction Connection .....	8
3.2.2	Discharge Connection .....	8
3.3	Electrical Connection.....	8
3.3.1	Wiring Diagram Single-Phase Motor.....	9
3.3.2	Wiring Diagram Three-Phase Motor.....	9
<b>4</b>	<b>Commissioning</b> .....	<b>10</b>
<b>5</b>	<b>Maintenance</b> .....	<b>11</b>
5.1	Maintenance Schedule.....	11
5.2	Cleaning from Dust and Dirt .....	12
<b>6</b>	<b>Overhaul</b> .....	<b>12</b>
<b>7</b>	<b>Decommissioning</b> .....	<b>13</b>
7.1	Dismantling and Disposal.....	13
<b>8</b>	<b>Spare Parts</b> .....	<b>13</b>
<b>9</b>	<b>Troubleshooting</b> .....	<b>14</b>

---

# 1 Safety

Prior to handling the machine, this instruction manual should be read and understood.

Read this manual carefully before use and keep for future reference.

This instruction manual remains valid as long as the customer does not change anything on the product.

The machine is intended for industrial use. It must be handled only by technically trained personnel.

Always wear appropriate personal protective equipment in accordance with the local regulations.

The machine has been designed and manufactured according to state-of-the-art methods. Nevertheless, residual risks may remain. This instruction manual highlights potential hazards where appropriate. Safety notes and warning messages are tagged with one of the keywords DANGER, WARNING, CAUTION, as follows:

## **DANGER**

... indicates an imminent dangerous situation that will result in death or serious injuries if not prevented.

---

## **WARNING**

... indicates a potentially dangerous situation that could result in death or serious injuries.

---

## **CAUTION**

... indicates a potentially dangerous situation that could result in minor injuries.

---

## 2 Product Description

Single-stage



Double- stage



IN Suction connection

OUT Discharge connection

### NOTE

Technical term.

In this instruction manual, we consider that the term 'machine' refers to the 'side channel blower'.

## 2.1 Operating Principle

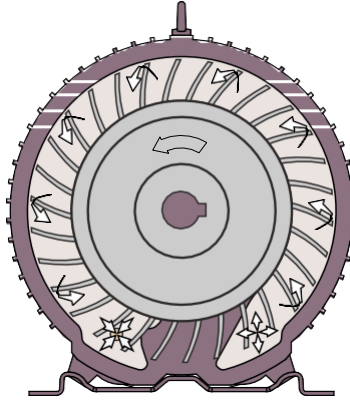

The machine works on the impulse principle, i.e. Kinetic energy is transferred from the impeller to the conveyed medium and then is converted into pressure.

The change in pressure is made without the use of any lubrication whatsoever.

### NOTICE

Lubricating a dry running machine (process chamber).

**Risk of damage to the machine!**

- Do not lubricate the process chamber of the machine with oil or grease.

## 2.2 Application

The machine is intended for the suction and/or compression of air and other dry, non-aggressive, non-toxic, non-flammable and non-explosive gases.

Conveying of other media leads to an increased thermal and/or mechanical load on the machine and is permissible only after a consultation with GOORUI.

The machine is intended for the placement in a non-potentially explosive environment.

The machine is not capable of maintaining ultimate pressure. The minimum allowed ultimate pressure is to be read from the nameplate of the machine.

By means of process control and/or vacuum relief valves it must be made sure that the minimum allowed ultimate pressure will not be under run.

Permitted environmental conditions, see Technical Data [► 16].

## 2.3 Optional Accessories

### 2.3.1 Pressure relief Valve

The pressure relief valve controls inlet pressure when the machine is used on vacuum duties.



---

The pressure regulating valve controls pressure when the machine is used on Overpressure duties.



### 2.3.2 Inlet Filter

The inlet filter protects the machine against dust and other solids in the process gas. The inlet filter is available with a cartridge.

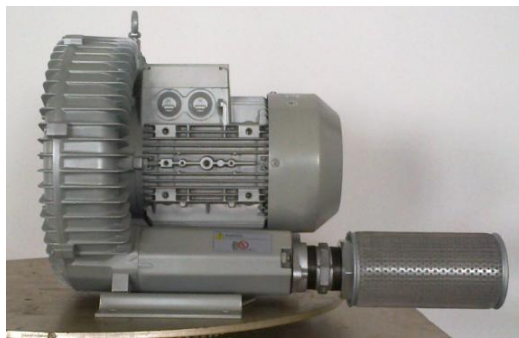

### 2.3.3 Silencer

A silencer at the discharge connection (OUT) can be provided to reduce the exhaust gas noise.



# 3 Installation

## 3.1 Installation Conditions

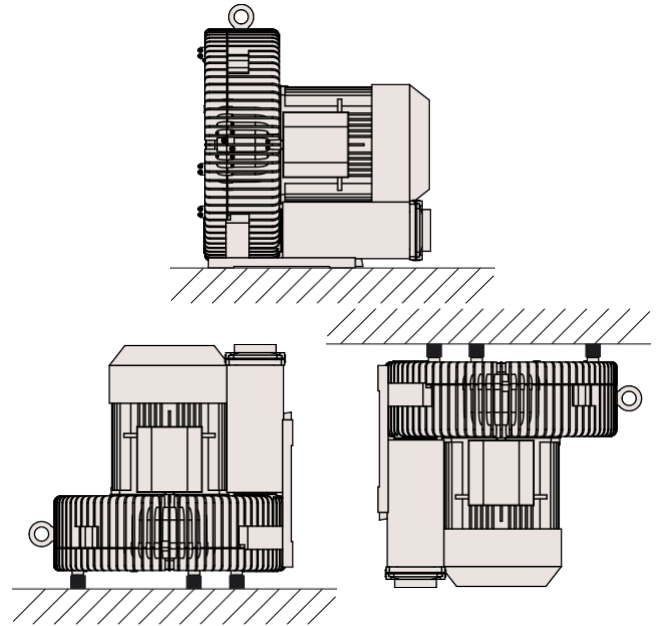
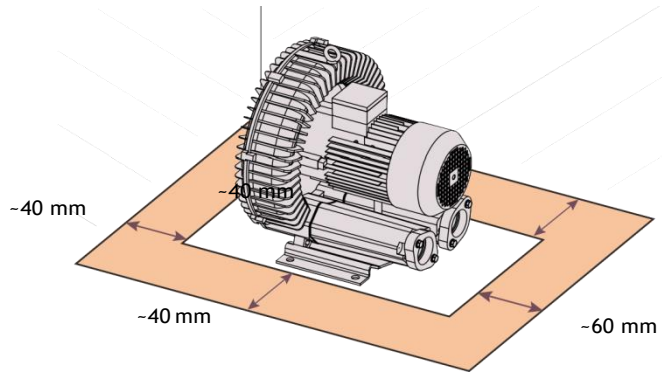

- Make sure that the environment of the machine is not potentially explosive.
- Make sure that the ambient conditions comply with the Technical Data [► 16].
- Make sure that the environmental conditions comply with the protection class of the motor.
- Make sure that the installation space or location is vented such that sufficient cooling of the machine is provided.
- Make sure that cooling air inlets and outlets are not covered or obstructed and that the cooling air flow is not affected adversely in any other way.
- Make sure that the machine is placed or mounted horizontally/vertically, with a maximum deviation of 1° in any direction.
- Make sure that the machine is placed or mounted horizontally on a flat surface.
- Make sure that all provided covers, guards, hoods, etc. are mounted.

If the machine is installed at an altitude greater than 1000 meters above sea level:

- Contact your sales representative, the motor should be de-rated or the ambient temperature limited.

If the machine is installed outdoor:

- Provide a protective cover against the weathering effects.

## 3.2 Connecting Lines / Pipes

- Remove all protective caps before installation.
- Make sure that the connection lines cause no stress on the machine's connection; if necessary use flexible joints.
- Make sure that the line size of the connection lines over the entire length is at least as large as the connections of the machine.

In case of very long connection lines it is advisable to use larger line sizes in order to avoid a loss of efficiency. Seek advice from your sales representative.

### 3.2.1 Suction Connection

#### NOTICE

Intruding foreign objects or liquids.

**Risk of damage to the machine!**

If the inlet gas contains dust or other foreign solid particles:

- Install a suitable filter (5 micron or less) upstream from the machine.

### 3.2.2 Discharge Connection

Depending on the specific order, other connection dimensions may apply.

- Make sure that the discharged gas will flow without obstruction. Do not shut off or throttle the discharge line.



## 3.3 Electrical Connection

### DANGER

Live wires.

**Risk of electrical shock.**

- Electrical installation work must only be executed by qualified personnel.
- Make sure that the power supply for the motor is compatible with the data on the nameplate of the motor.
- Provide overload protection according to EN 60204-1 for the motor.
- Make sure that the motor of the machine will not be affected by electric or electro-magnetic disturbance from the mains; if necessary seek advice from your sales representative.
- Connect the protective ground conductor.
- Electrically connect the motor.

### NOTICE

Incorrect connection.

**Risk of damage to the motor!**

- The wiring diagrams given below are typical. Check the inside of the terminal box for motor connection instructions/diagrams.

### 3.3.1 Wiring Diagram Single-Phase Motor

-Models: GHBH XXX 12 XXX 220V, 1 Phase

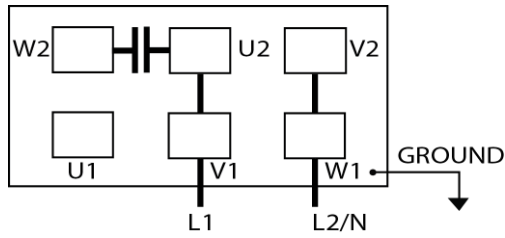

### 3.3.2 Wiring Diagram Three-Phase Motor

#### NOTICE

Incorrect direction of rotation.

**Risk of damage to the machine!**

- Operation in the wrong direction of rotation can destroy the machine in a short time!  
Prior to start-up, ensure that the machine is operated in the right direction.

If the rotation of the motor must be changed:

- Switch any two of the motor phase wires.

-Models: GHBH XXX 34 XXX 220V/480V 3 Phase

-Models: GHBG XXX 34 XXX 220V/480V 3 Phase

**DELTA CONNECTION 220V, 3PHASE**

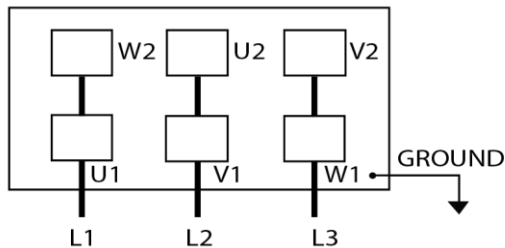

**STAR CONNECTION 480V, 3PHASE**

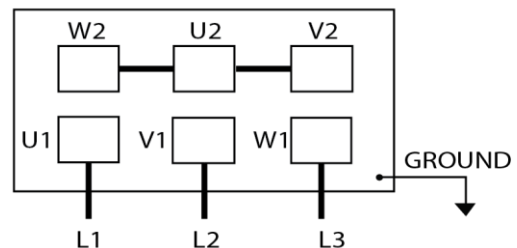

-Models: GHBH XXX 36 XXX 480V/720V 3 Phase

-Models: GHBG XXX 36 XXX 480V/720V 3 Phase

**DELTA CONNECTION 480V, 3PHASE**

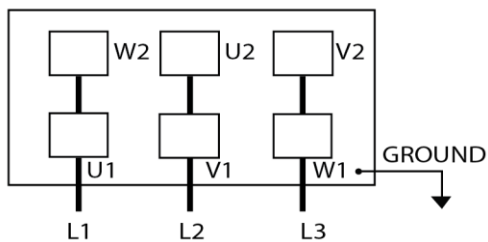

**STAR CONNECTION 720V, 3PHASE**

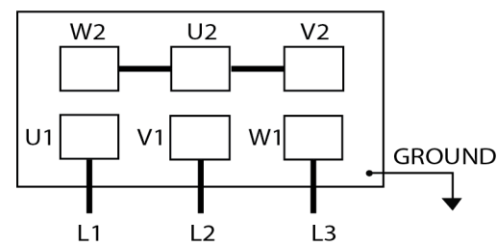

---

## 4 Commissioning

### NOTICE

Lubricating a dry running machine (process chamber).

**Risk of damage to the machine!**

- Do not lubricate the process chamber of the machine with oil or grease.

### CAUTION

During operation the surface of the machine may reach temperatures of more than 70°C.

**Risk of burns!**

- Avoid contact with the machine during and directly after operation.



### CAUTION

Noise of running machine.

**Risk of damage to hearing!**

If persons are present in the vicinity of a non-noise insulated machine over extended periods:

- Make sure that ear protection is being used.
- Make sure that the installation conditions (see Installation Conditions [▶ 7]) are complied with.
- Switch on the machine.
- Make sure that the maximum permissible number of starts does not exceed 6 starts per hour.
- Make sure the working/pause periods are equal with multiple starts per hour. As soon as the machine is operated under normal operating conditions:
- Measure the motor current and record it as reference for future maintenance and trouble shooting work.

# 5 Maintenance



## WARNING

Machines contaminated with hazardous material.

**Risk of poisoning!**

**Risk of infection!**

If the machine is contaminated with hazardous material:

- Wear appropriate personal protective equipment.

## CAUTION

Hot surface.

**Risk of burns!**

- Prior to any action requiring touching the machine, let the machine cool down first.
- Shut down the machine and lock against inadvertent start up.
- Vent the connected lines to atmospheric pressure.

If necessary:

- Disconnect all connections.

## 5.1 Maintenance Schedule

The maintenance intervals depend very much on the individual operating conditions. The intervals given below are desired to be considered as starting values which should be shortened or extended as appropriate. Particularly heavy duty operation, such as high dust loads in the environment or in the process gas, other contamination or ingress of process material, can make it necessary to shorten the maintenance intervals significantly.

Interval	Maintenance work
Monthly	<ul style="list-style-type: none"><li>• Clean the machine from dust and dirt.</li></ul> in case of an inlet filter being installed: <ul style="list-style-type: none"><li>• Check the inlet filter cartridge, replace if necessary.</li></ul>
Every 6 months	<ul style="list-style-type: none"><li>• Clean the machine from dust and dirt.</li><li>• Make sure that the electronic components and the cooling fan are free from dust.</li></ul>
Yearly	<ul style="list-style-type: none"><li>• Carry out a visual inspection and clean the machine from dust and dirt.</li><li>• Check the electrical connections and the monitoring devices.</li><li>• Clean the inlet and outlet silencer.</li></ul>
Every 5 years	<ul style="list-style-type: none"><li>• Have a major overhaul on the machine (contact your sales representative ).</li></ul>

## 5.2 Cleaning from Dust and Dirt

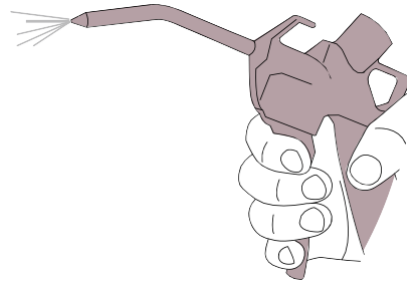
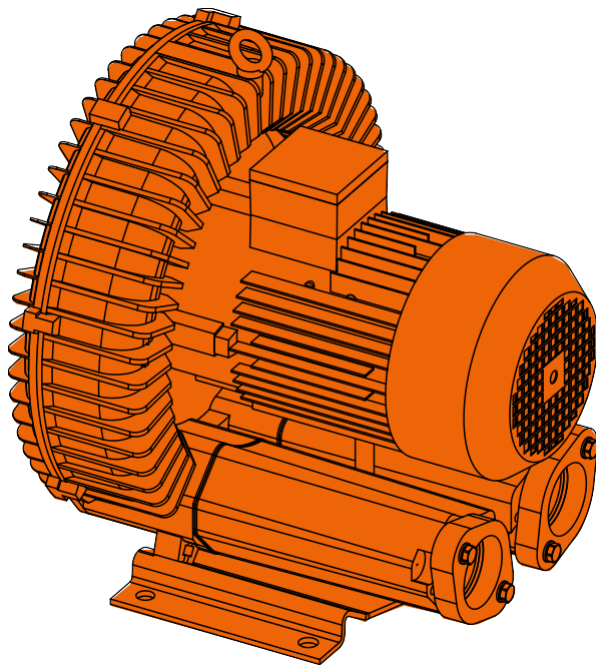

Clean the ventilation grilles  
and cooling fins

## 6. Overhaul

### NOTICE

Improper assembly.

**Risk of premature failure!**

**Loss of efficiency!**

- It is highly recommended that any dismantling of the machine that goes beyond anything that is described in this manual should be done through GOORUI.



### WARNING

Machines contaminated with hazardous material.

**Risk of poisoning!**

**Risk of infection!**

If the machine is contaminated with hazardous material:

- Wear appropriate personal protective equipment.

In case of the machine having conveyed gas that was contaminated with foreign materials which are dangerous to health:

- Decontaminate the machine as well as possible and state the contamination status in a 'Declaration of Contamination'.

---

## 7 Decommissioning

- Shut down the machine and lock against inadvertent start up.
- Vent the connected lines to atmospheric pressure.
- Disconnect all connections.

If the machine is going to be stored:

- See Storage [▶ 6].

### 7.1 Dismantling and Disposal

- Separate special waste from the machine.
- Dispose of special waste in compliance with applicable regulations.
- Dispose of the machine as scrap metal.

## 8 Spare Parts

### NOTICE

Use of non-GOORUI genuine spare parts.

**Risk of premature failure!**

**Loss of efficiency!**

- The exclusive use of GOORUI genuine spare parts and consumables is recommended for the proper function of the machine and for granting of warranty.

---

Commercially available standard parts are to be purchased on the open market. If other parts are required:

- Contact your sales representative for the detailed spare parts and accessory list.

## 9. Troubleshooting

### DANGER

Live wires.

**Risk of electrical shock.**

- Electrical installation work must only be executed by qualified personnel.

### CAUTION

Hot surface.

**Risk of burns!**

- Prior to any action requiring touching the machine, let the machine cool down first.

Problem	Possible Cause	Remedy
The machine does not start.	At least two power supply leads are interrupted	• Check the fuses, terminals and power supply cables
	The motor is not supplied with the correct voltage.	• Check the power supply.
	The motor is defective.	• Repair the machine ( contact us ).
The machine does not start; humming noise.	One power supply lead is interrupted	• Check the fuses, terminals and power supply cables
	Impeller defective	• Replace impeller
	Impeller is jammed	• Open the cover, remove foreign body and clean. • Check the impeller gap.
	Bearing on motor side machine side is defective	• Replace defective bearing.
Motorprotectives witch trips when starting the machine. Power consumption is too high.	Winding short-circuit	• Check the winding.
	Motor overloaded. Throttling does not match specification on rating plate	• Reduce throttling. • Clean filters, mufflers and connecting pipes.
	Compressor is jammed.	• See The machine does not start; humming noises [ ► 14].
The machine runs very noisily.	The machine runs in the wrong direction	• Check the direction of rotation.
	Bearings lacking grease	• Relubricate or replace if necessary.
	Defective bearings.	• Repair the machine ( contact us ).
The machine runs with abnormal flow noises.	The flow speed is too high	• Use larger sized pipes.
	The silencers are soiled.	• Check silencer inserts, clean or replace if necessary.

The machine does not reach the usual pressure on the suction connection.	Suction or discharge lines too long or section diameter too small.	<ul style="list-style-type: none"> <li>• Use larger diameter or shorter lines.</li> <li>• Seek advice from your local sales representative.</li> </ul>
	The machine runs in the wrong direction.	<ul style="list-style-type: none"> <li>• Check the direction of rotation, see Wiring Diagram Three-Phase Motor</li> </ul>
	Different density of conveyed medium	<ul style="list-style-type: none"> <li>• Take conversion of pressure value into account. Contact us if necessary.</li> </ul>
	Change in blade profile due soiling.	<ul style="list-style-type: none"> <li>• Check the impeller, clean or replace if necessary.</li> </ul>
	In case an inlet screen is installed: The inlet screen is partially clogged.	<ul style="list-style-type: none"> <li>• Clean the inlet screen.</li> </ul>
	In case a vacuum relief valve is installed: The vacuum relief valve is misadjusted or defective.	<ul style="list-style-type: none"> <li>• Replace the vacuum relief valve.</li> </ul>
	In case an inlet filter valve is installed: The inlet filter cartridge is partially clogged.	<ul style="list-style-type: none"> <li>• Replace the inlet filter cartridge.</li> </ul>
	Leak in the system.	<ul style="list-style-type: none"> <li>• Repair leak.</li> </ul>
	Internal parts are worn or damaged.	<ul style="list-style-type: none"> <li>• Repair the machine (contact us).</li> </ul>
The machine runs too hot.	Insufficient cooling.	<ul style="list-style-type: none"> <li>• Remove dust and dirt from the machine.</li> </ul>
	Ambient temperature too high.	<ul style="list-style-type: none"> <li>• Observe the permitted ambient temperature.</li> </ul>
Compressor leaky.	Seals on silencer defective.	<ul style="list-style-type: none"> <li>• Check silencer seals and replace if necessary</li> </ul>
	Seals in motor area defective.	<ul style="list-style-type: none"> <li>• Check motor seals and replace if necessary</li> </ul>

For the solution of problems not mentioned in the troubleshooting chart contact your sales representative.